

Force, Motion, and Energy- 5.6A(R), 5.6B(R), 5.6D(S)

Name _____

1. Students are investigating light energy using a flashlight. One group could not get their flashlight to produce light. Which of these changes should be made to the flashlight?

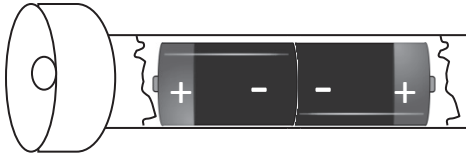

- (A) Replace the bulb.
- (B) Shake the flashlight to see if any of the wires in the circuit have come loose.
- (C) Turn one of the batteries so the positive end and the negative ends are touching.
- (D) Turn the batteries so the two positive ends are touching.

2. A power plant uses geothermal energy to produce electricity. Heat from the Earth's surface makes the turbine spin. What type of energy is used to make the turbine spin in this power plant?

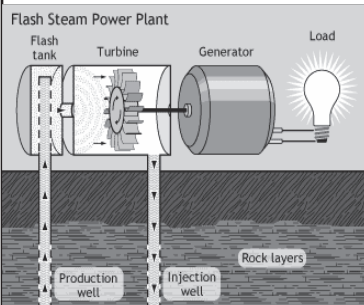

- (F) Sound Energy
- (G) Electrical Energy
- (H) Light Energy
- (J) Mechanical Energy

3. During an experiment, an aluminum thermometer is placed in a pot of water and then put on a hot plate. A student checks the temperature of the water, and notices the other end of the thermometer is warm. What type of energy traveled through the aluminum thermometer to his hand?

- (A) Thermal
- (B) Solar
- (C) Mechanical
- (D) Light

4. Students are testing the height of ramps and their effect on the distance a marble will travel. The students test the experiment by placing the marble at the top of the ramp and letting go without pushing it. What force is being applied to the marble, causing it to move down the ramp?

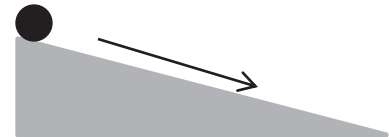

- (F) Magnetism
- (G) Gravity
- (H) Friction
- (J) Air Pressure

5. A wind turbine spins and converts energy of motion into electrical energy used to power factories and homes. Which type of energy is used to make the turbine spin?

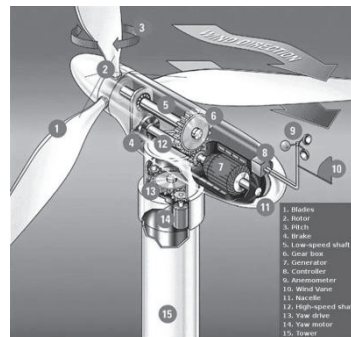

- (A) Electrical
- (B) Sound
- (C) Light
- (D) Mechanical

6. The diagram below shows an open circuit. Which object should be added to the end of the wires to make the bell ring?

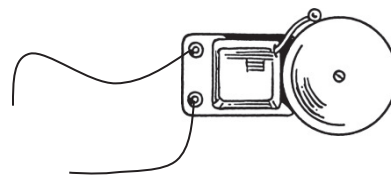

- (F) Light bulb
- (G) Knife switch
- (H) Energy source
- (J) Aluminum foil

Force, Motion, and Energy- 5.6A(R), 5.6B(R), 5.6D(S)

Name _____

7. Which object in the chart below is most likely a lamp?

OBJECT	USES	PRODUCES
1	Electric Energy	Sound Energy
2	Light Energy	Mechanical Energy
3	Electrical Energy	Light Energy
4	Solar Energy	Heat Energy

- (A) Object 1 (B) Object 4
 (C) Object 3 (D) Object 2

8. Robbie uses a pulley and a spring scale to lift up an object with a mass of 10 grams. Robbie repeats this process except changes the mass of the object to 30 grams, and then 50 grams.

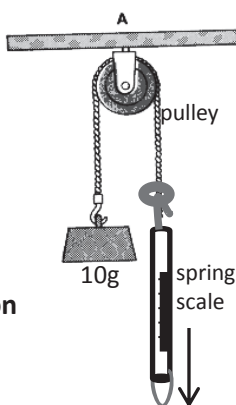

Which question is this investigation most likely designed to answer?

- (F) How do different masses affect spring scales?
 (G) How does the mass of an object affect the amount of force needed to lift it?
 (H) How does a spring scale react with a pulley?
 (J) How does a spring scale work?

9. Julie is using a campfire to roast marshmallows. The campfire produces-

- (A) electrical and heat energy.
 (B) sound and solar energy.
 (C) heat and mechanical energy.
 (D) light and heat energy.

10. The picture below is a light switch.



When the light switch is in the ON position, lights in a classroom will come on. This happens because--

- (F) the switch opens the circuit allowing electricity to flow through.
 (G) the switch closes the circuit allowing electricity to flow through.
 (H) the switch creates a better conductor of electricity.
 (J) the switch creates sound energy allowing electricity to flow through.

11. An acoustic guitar has strings and a soundhole. How does the acoustic guitar work to create sound?



- (A) Vibrations from the string creates sound.
 (B) The position of the guitar creates sound.
 (C) Electrical energy creates the sound.
 (D) The soundhole alone produces sound.

12. A group of students want to know if the surface of a ramp will have an effect on the distance traveled by a toy car. Which variable should the students change to get a fair test?

- (F) The height of the ramp (G) The surface of the ramp
 (H) The force they use to push the car down the ramp (J) The toy car